

# Soluzioni digitali per lo sviluppo delle PMI italiane: una piattaforma pronta all'uso

ANDREA GOZZI

# Siemens Knows IoT and Connected Devices

**Siemens is the #1 automation provider,** delivering mission critical operation and automation technology, with **30M automation systems, 75M contracted smart meters.** And Siemens already has **over 800K connected products in the field today.**



## MindApps

Powerful industry applications and digital services for asset transparency and analytical insights

## MindSphere

Open Platform as a Service (PaaS) for scalable, global IoT connectivity and application development

## MindConnect

Secure plug and play connection of Siemens and third-party products and equipment

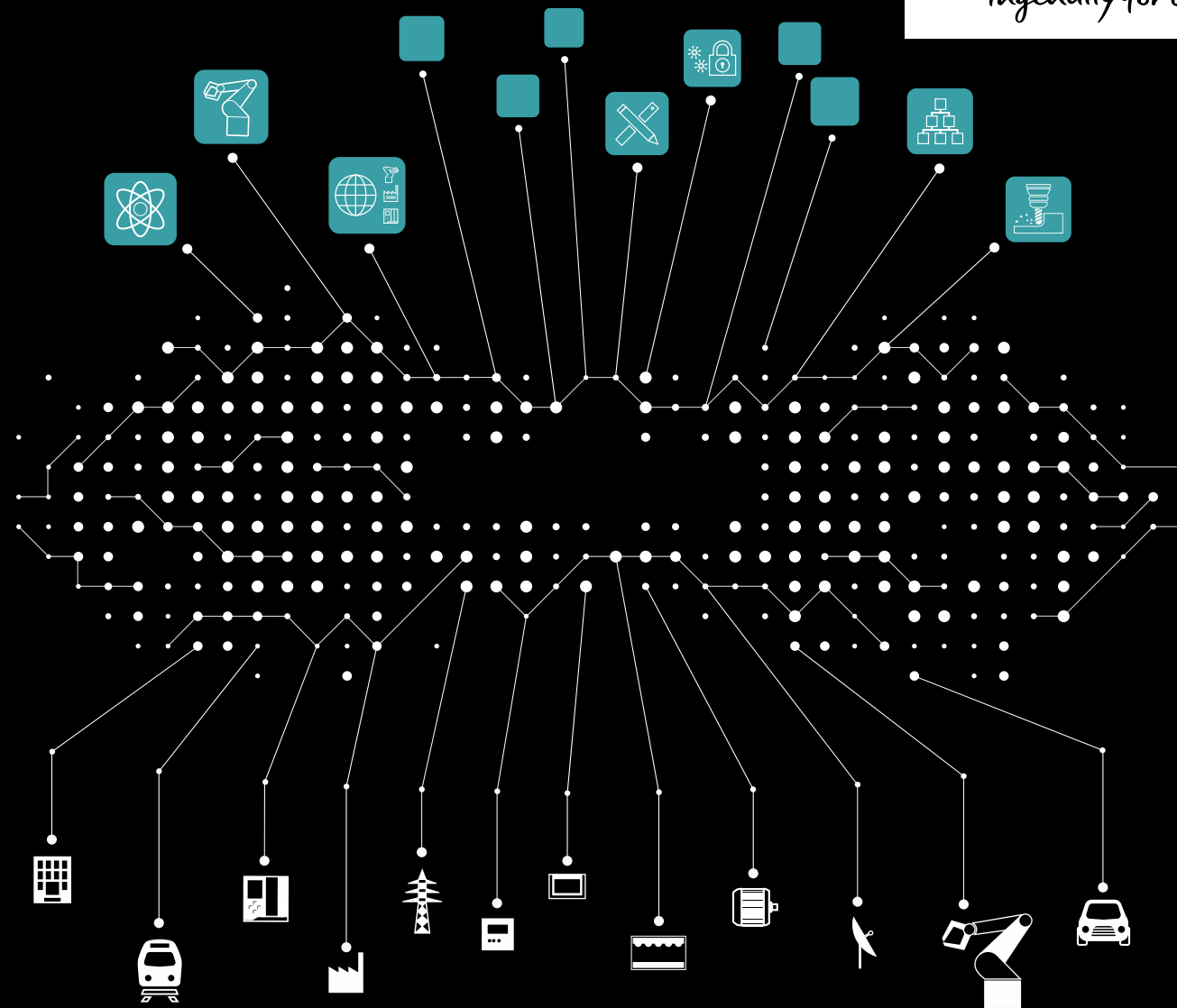

**MindSphere - The cloud-based, open IoT Operating System**

## Increase Performance ...

...powered by digital transformation

## Build Digital Business ...

...through development of applications & digital services

## Differentiate in the Market ...

...through new service and business models



# SIEMENS

*Ingenuity for life*

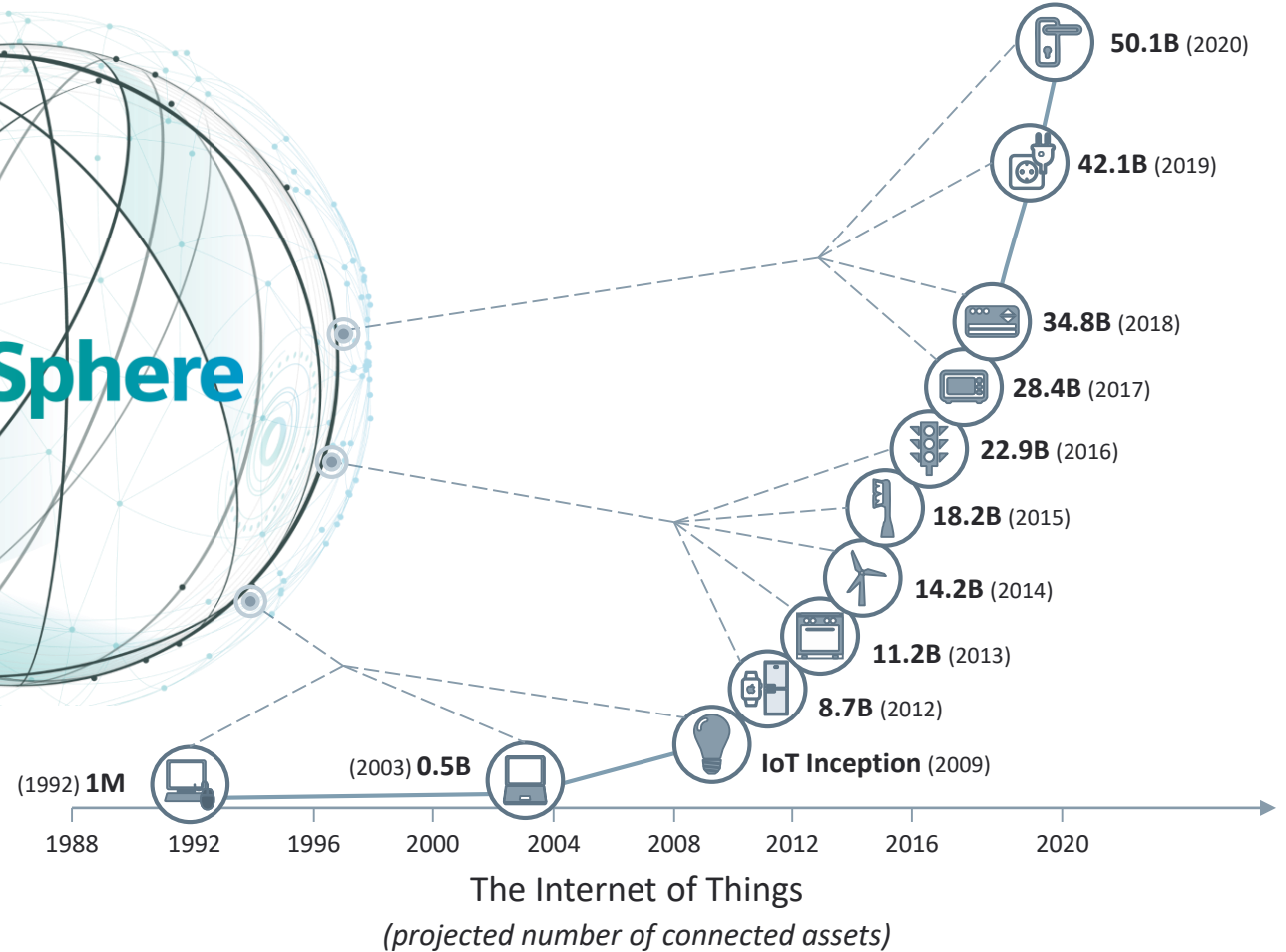

**Majority of all assets will be connected within a short time frame**

**How to generate  
value with the smart  
interaction of OT/IT?**

# Smart OT/IT interaction drives...

**SIEMENS**  
*Ingenuity for life*



**Speed**



**Flexibility**



**Quality**

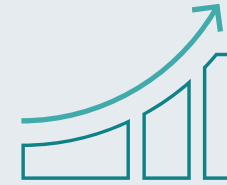

**Efficiency**



**New business models**



**Security**





# OT / IT interplay from the Siemens factory in Amberg, Germany





**OT / IT use-case from  
the Siemens factory  
in Amberg, Germany**



# What is the challenge @ the soldering line at our Digital Factory

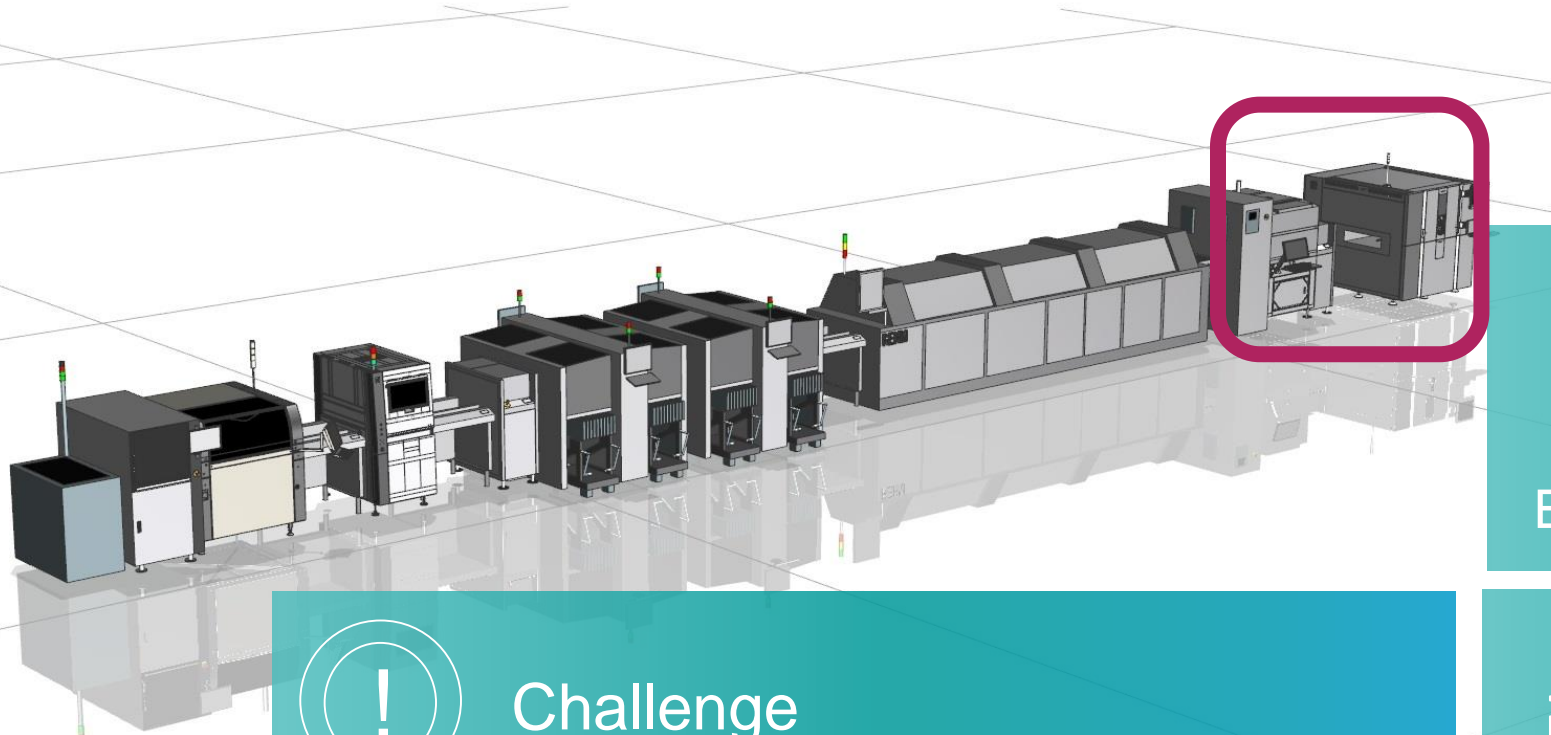

Quality

Ensure 100% Quality



Challenge

Production bottleneck



Efficiency

Increase production output w/o rising labor costs & investment

# OT – Operational Technology: 60 years of experiences with Totally Integrated Automation

**SIEMENS**  
*Ingenuity for life*

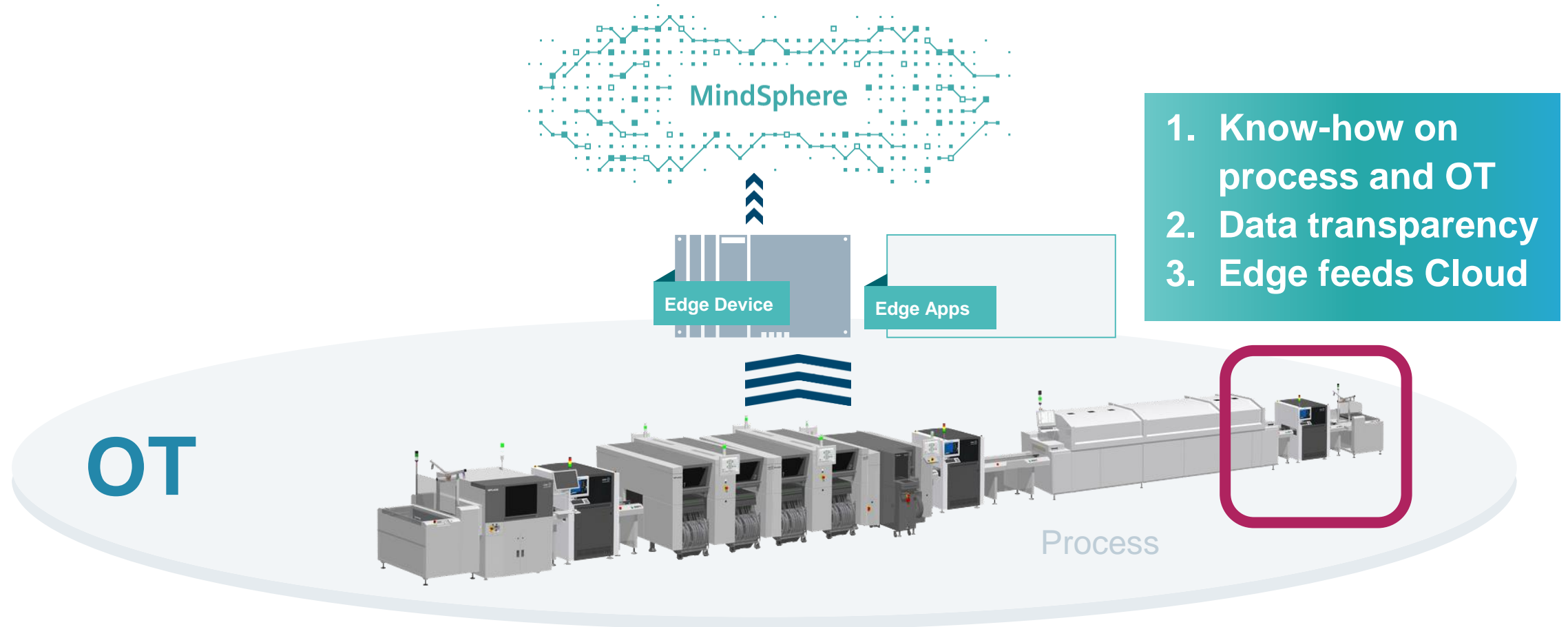



# IT – Information Technology: MindSphere, the future of operating Systems

**SIEMENS**  
*Ingenuity for life*

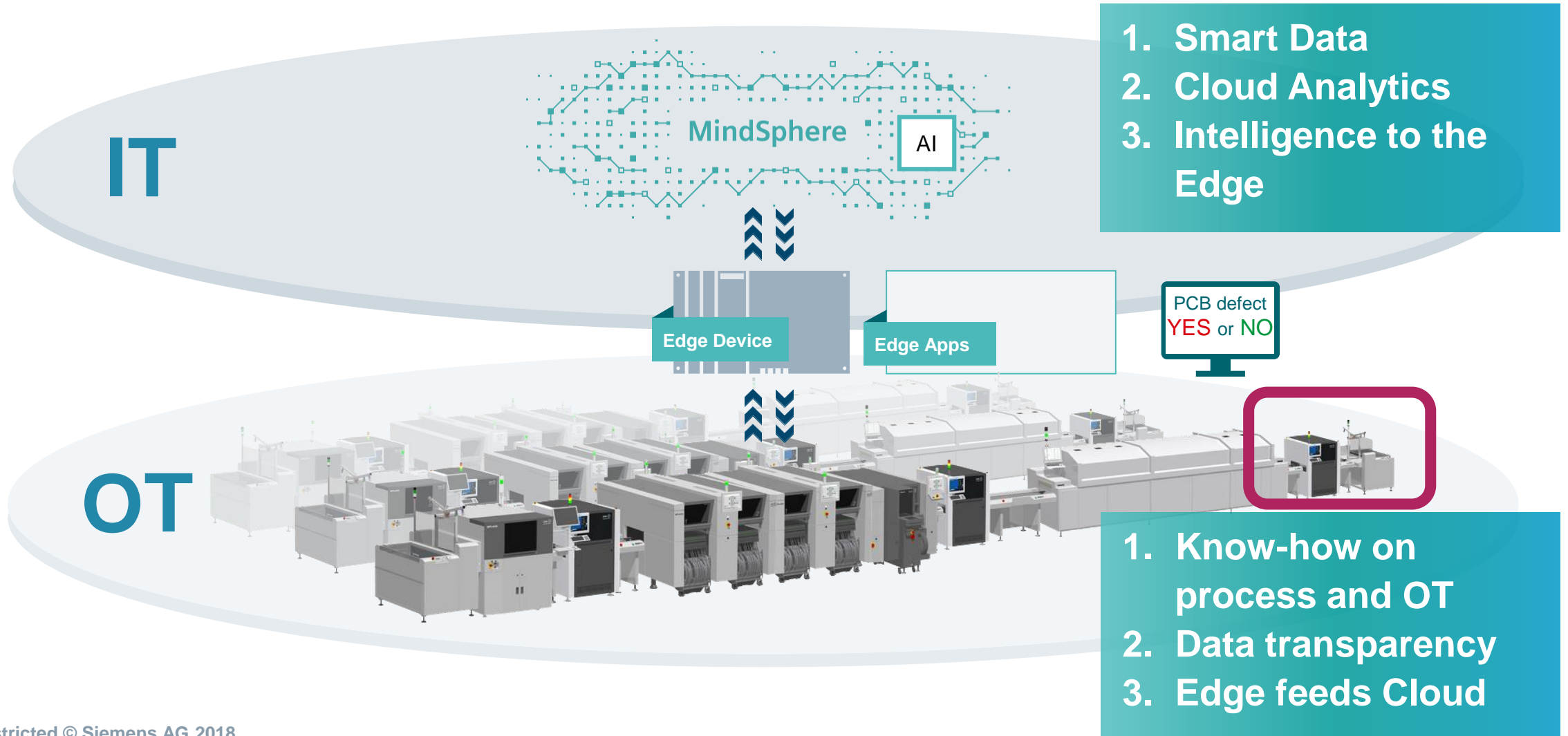

With the smart interaction of OT/IT, Siemens factory in Amberg has solved a bottleneck problem in the PCB production line...

**SIEMENS**  
*Ingenuity for life*



**30% increase**  
of output quantity



**Savings** of  
labor costs and investments



ensure **100%**  
**Quality** of PCB's





# How can I acquire the current conditions of my machine tools and increase production transparency?



Is my machine tool in a productive condition?

What is the capacity utilization of my machine when planned and actual values are compared?



**With Analyze MyPerformance, a targeted weak point analysis and therefore production optimization is possible**



How do my individual machine productivities compare with other production lines?

How high is the overall equipment efficiency of my machine tool?



# Top highlights of first version Analyze MyPerformance /OEE-Monitor

Transparency of the production status enables ...

... optimized planning of utilization and usage



... a wide range of standard evaluations



- Plant monitoring
- Availability and analysis
- Indicator for current production level
- Overall equipment efficiency (OEE indicators)

... longer machine operating times



... wide range of connectable controller types



... recording of machine operating times conditions



- Machine operating times and conditions
- Number of workpieces
- Differentiation in good and bad parts

... higher levels of availability and productivity





# Higher productivity of machine tools thanks to new knowledge and transparency

**SIEMENS**  
*Ingenuity for Life*

## Production



More transparency regarding utilization of machine tool capacity



Increased productivity, reliability, and availability



Lower production costs based on more precise planning

## The solution

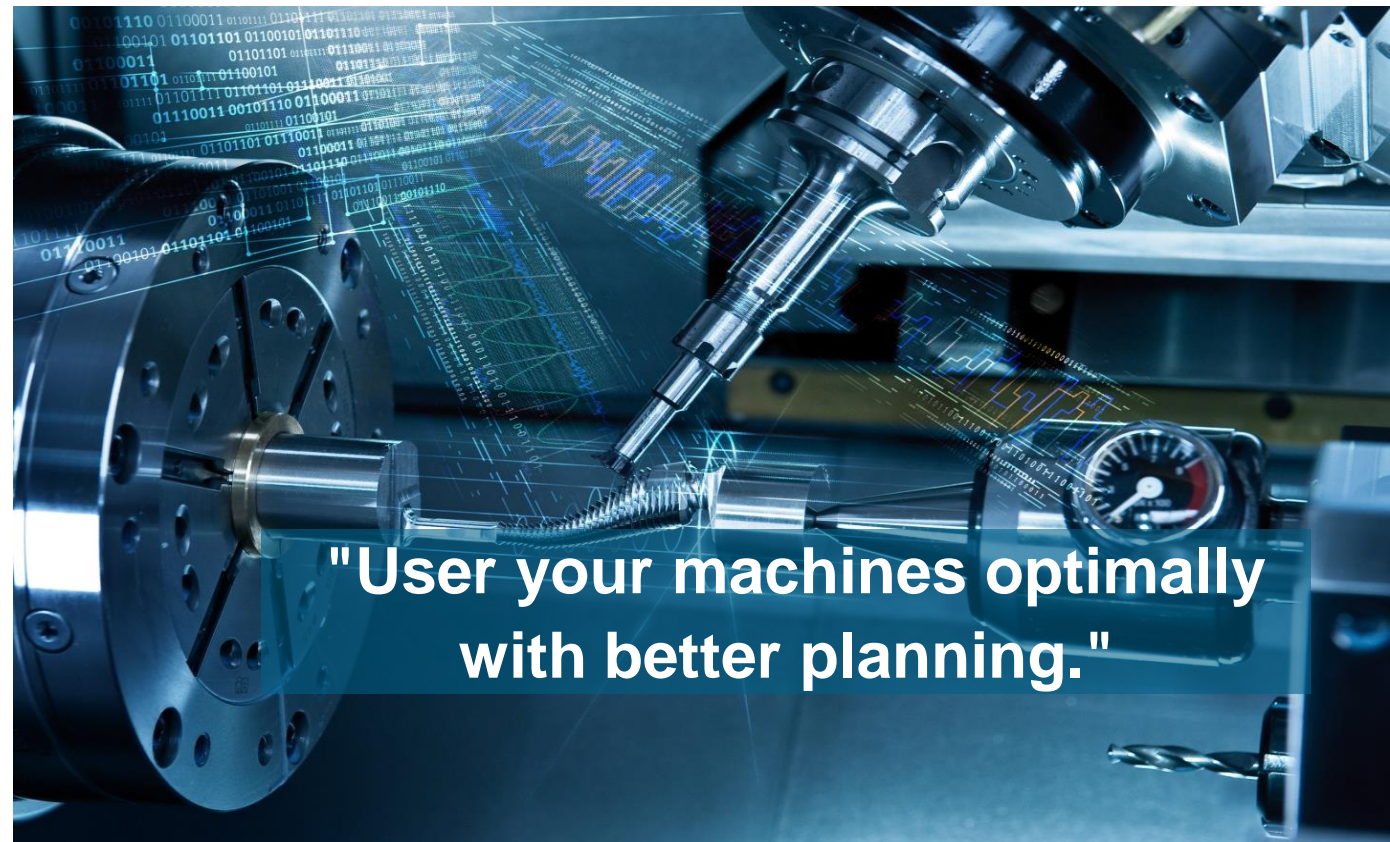

**"User your machines optimally  
with better planning."**

# How can I make my cutting process more productive?



Can I increase **machine availability** by elimination varying effects of cutting conditions?

How can I achieve **optimum utilization** of machine and tools?



**Adaptive Control and Monitoring**



Is there a simple way to **reduce cycle time**?

How can I give a give solution for **extending tool life**?





# ACM (Adaptive Control and Monitoring)

## Main features and added value

**SIEMENS**  
*Ingenuity for life*

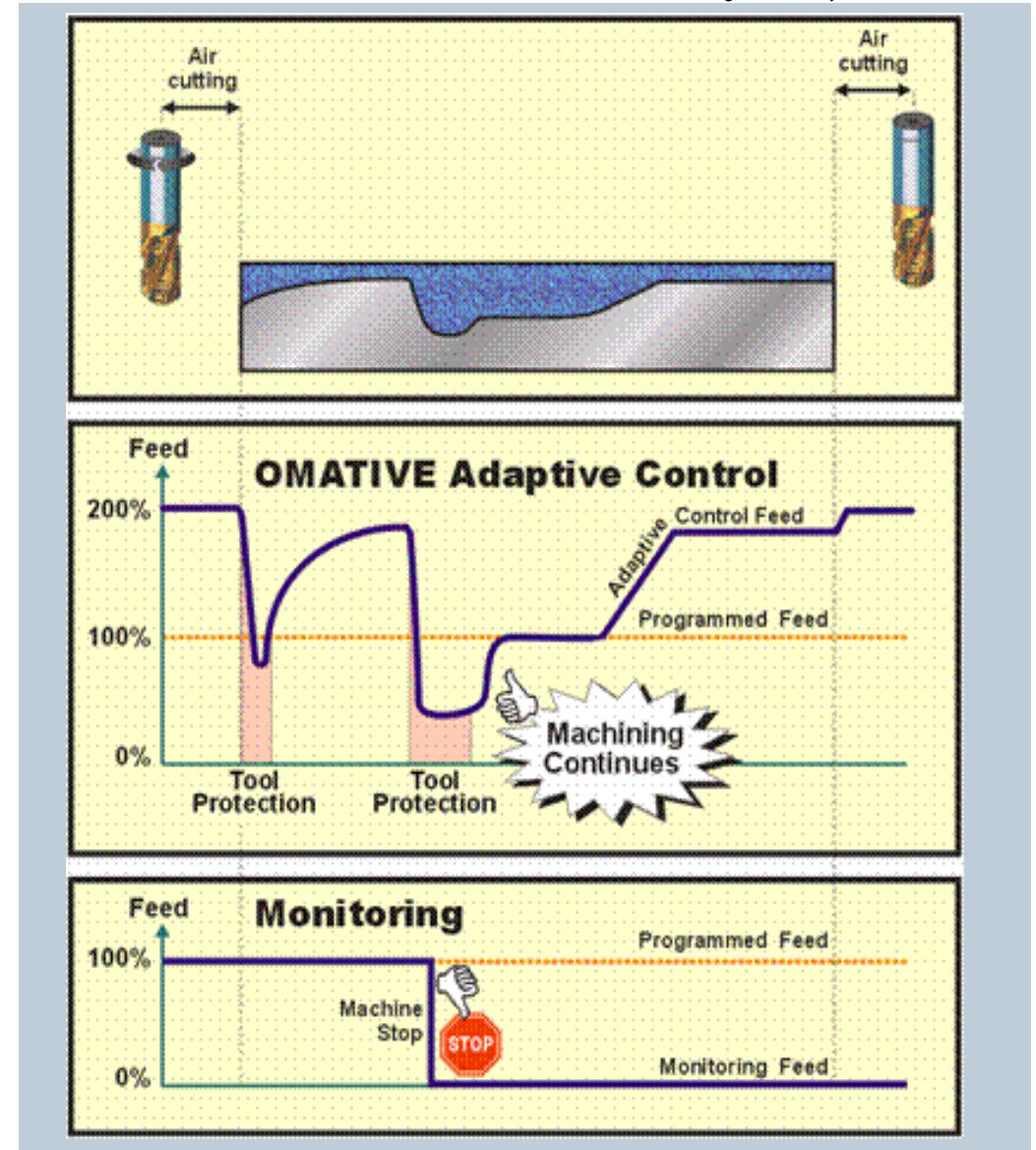

# ACM – top highlights

Increased productivity, quality and availability

**SIEMENS**  
*Ingenuity for life*

... Cycle time reduction



... Increased machine capacity



... Consistently high workpiece quality



... Reduction in downtime

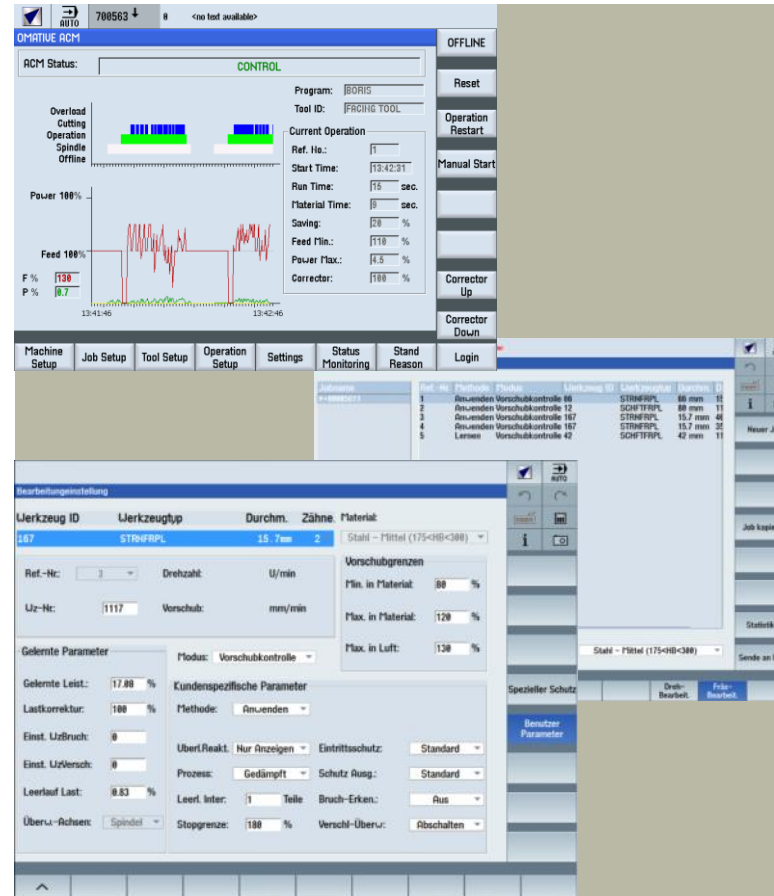

... Optimal utilization of machine and tools



... Elimination of damage to machine tool, fixture and part



... Tool life extension



... Increasing machine operating flexibility





# Thank you for your attention

**SIEMENS**  
*Ingenuity for life*

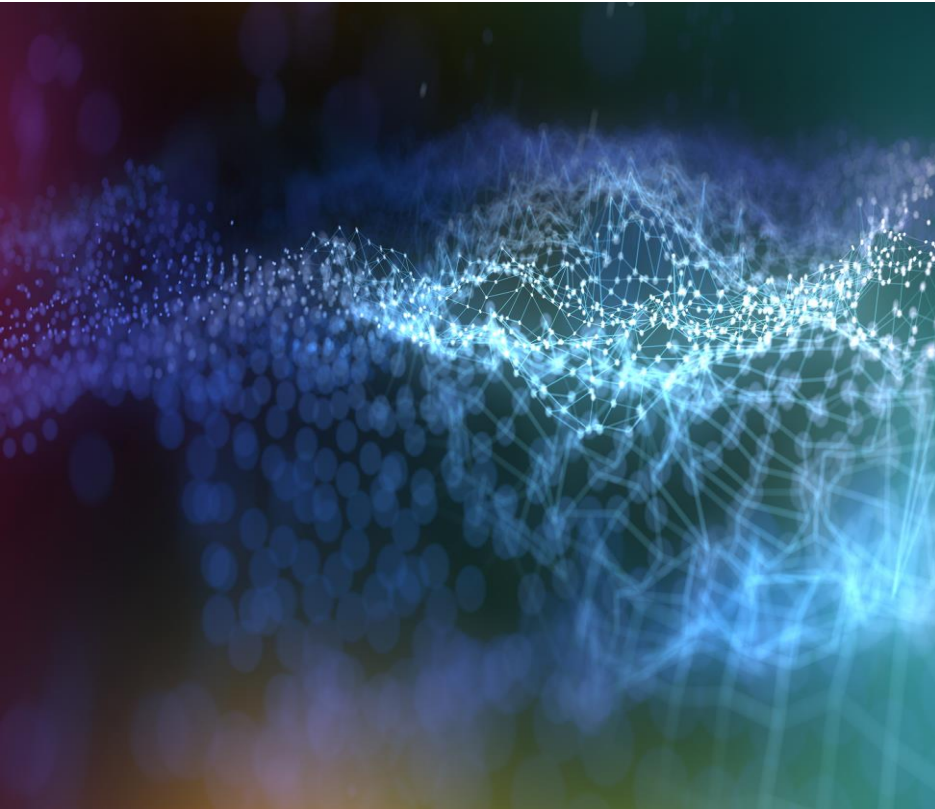

Subject to changes and errors. The information given in this document only contains general descriptions and/or performance features which may not always specifically reflect those described, or which may undergo modification in the course of further development of the products. The requested performance features are binding only when they are expressly agreed upon in the concluded contract.

All product designations, product names, etc. may contain trademarks or other rights of Siemens AG, its affiliated companies or third parties.

Their unauthorized use may infringe the rights of the respective owner.