



Rispondere alla variabilità della domanda, stabilizzando la Supply Chain con la matrice ABCX: il caso Varvel

Mauro Cominoli
Francesco Curcio

Fabbrica Futuro - 6 Marzo 2013



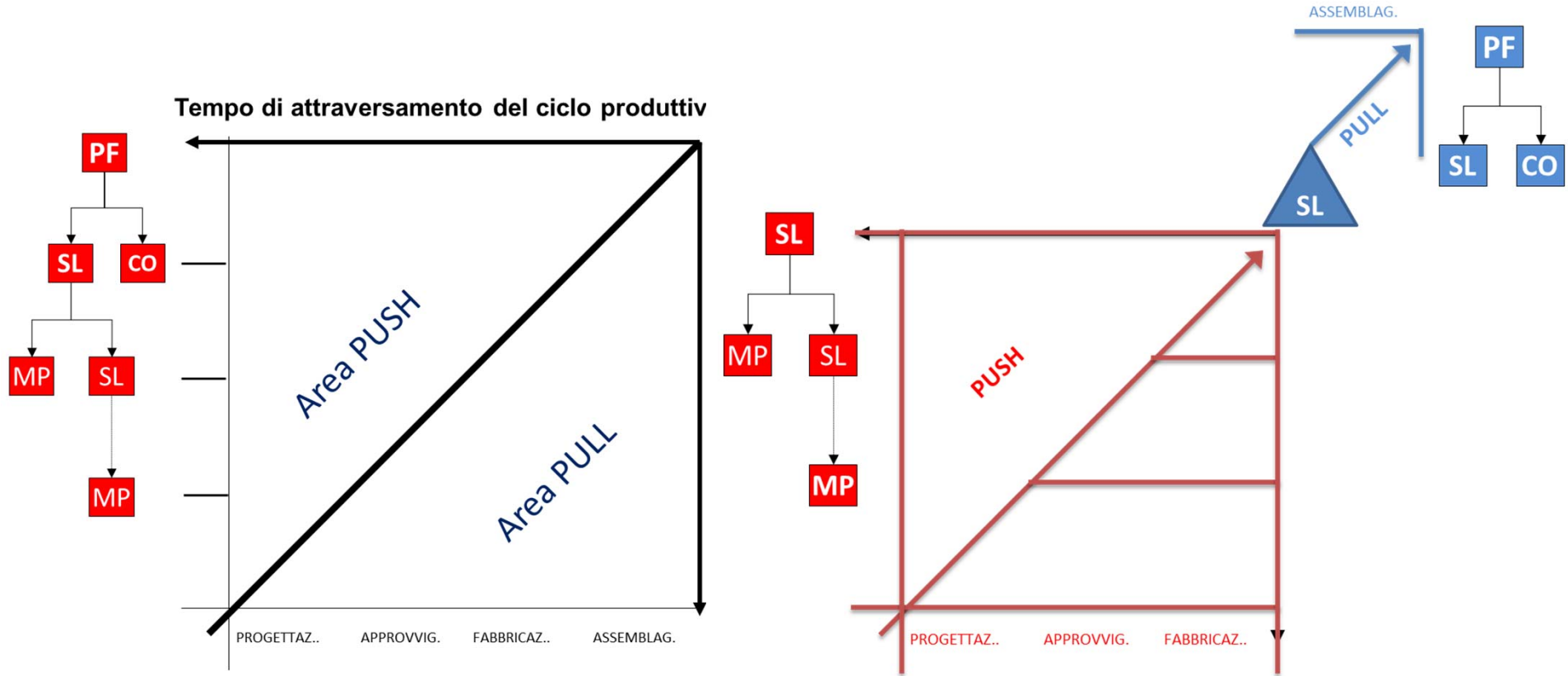



I numeri di Varvel

Capitale sociale: 2.000.000 Euro

Anno di fondazione: 1955

Personale: 150 addetti (incluse consociate)

Fatturato 2012: 29.150.000 Euro

(il 40% in Italia e il 60% all'estero)

Gli stabilimenti Varvel, di recente realizzazione, sorgono su un'area complessiva di 40.000mq nella zona industriale di Crespellano (Bologna)





LA MISSION

Essere un **partner affidabile** nella produzione e commercializzazione su scala internazionale di organi di trasmissione per mezzo di un **elevato livello di servizio**, la **modularità dei prodotti** e la **personalizzazione delle soluzioni**, nel rispetto dei valori **dell'impresa socialmente responsabile**.

10 gamme prodotti
Da 4 a 9 grandezze
25 varianti

oltre 10.000 codici di
prodotti finiti
oltre 5.000 componenti





IL GRUPPO VARVEL



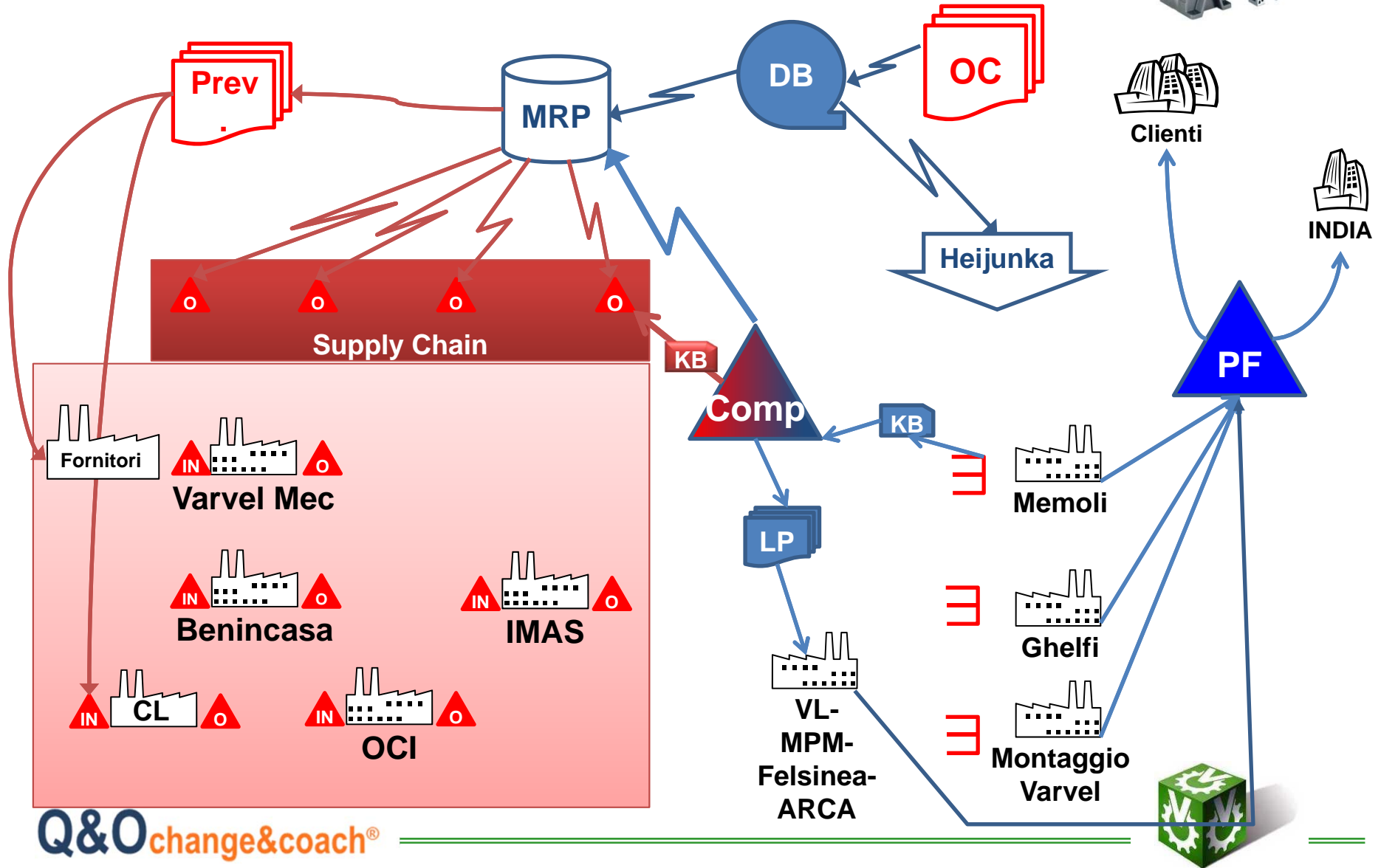

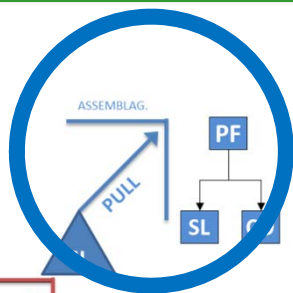

1° STEP: FABBRICA BLU

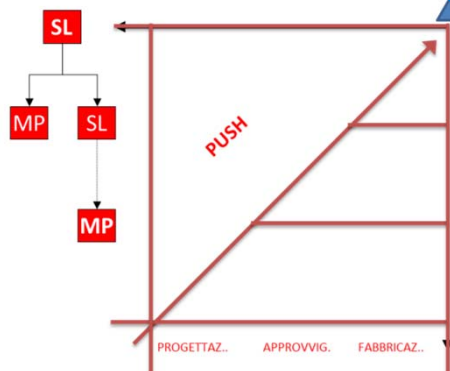

- definire un nuovo lay-out dei banchi di montaggio
- studiare le postazioni di lavoro da un punto di vista ergonomico, efficiente, efficace
- definire le modalità di alimentazione dei materiali verso le linee
- definire le modalità di gestione dei prodotti assemblati
- definire i percorsi pedonali



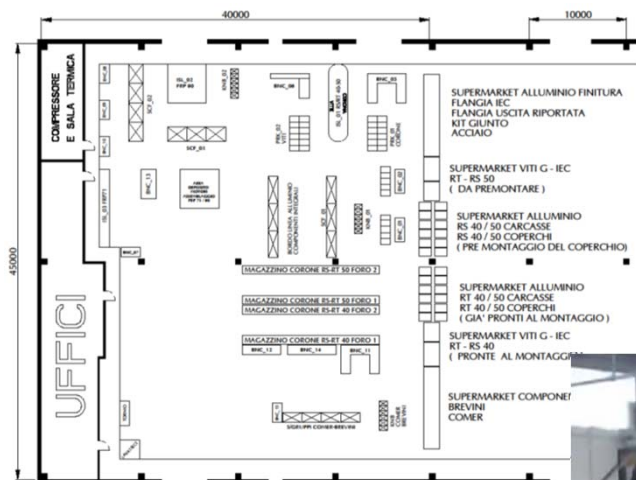

Spazi occupati

- 50%

Produzione giornaliera

+ 30%

Tempo di risposta

- 75%



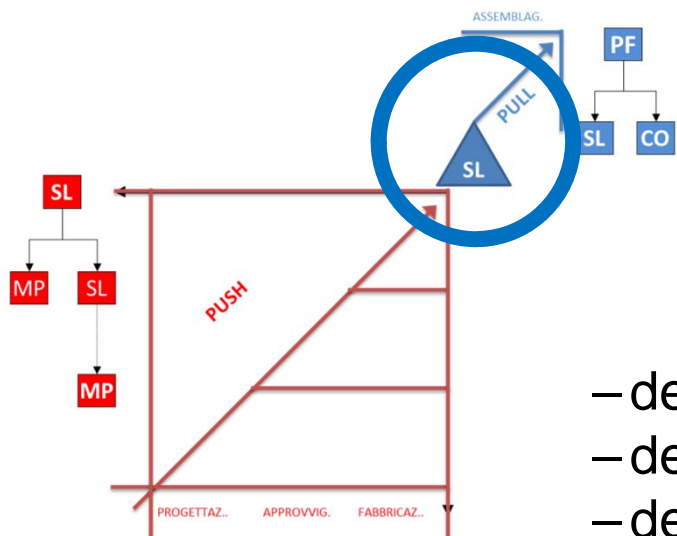

2° STEP: DISACCOUPLATORE

- determinare il giusto livello di servizio
- definire le logiche di gestione dei materiali
- determinare il livello obiettivo
- attivare politiche di refilling coerenti



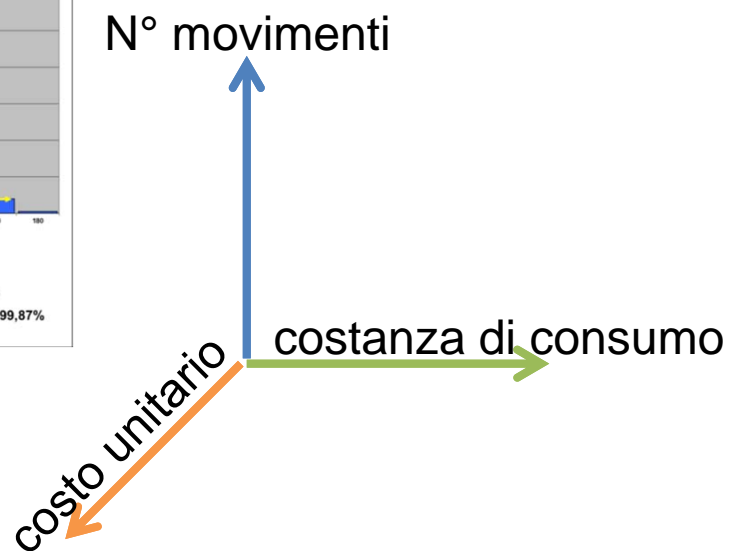
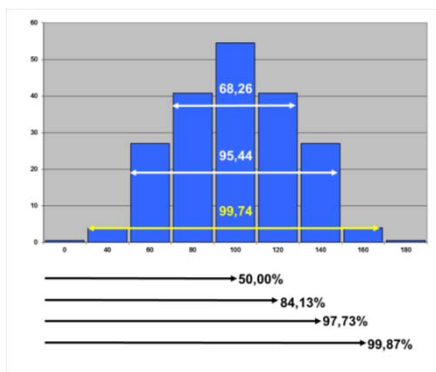
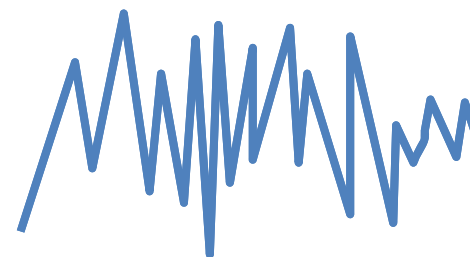
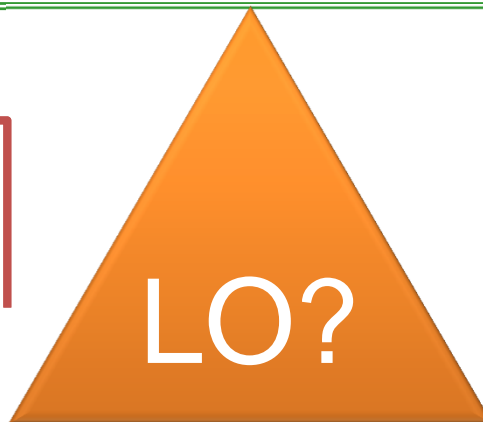

Aumento per 6 mesi dovuto a:

- smaltimento overstock
- riempimento livelli obiettivo

A fine 2012
-12%



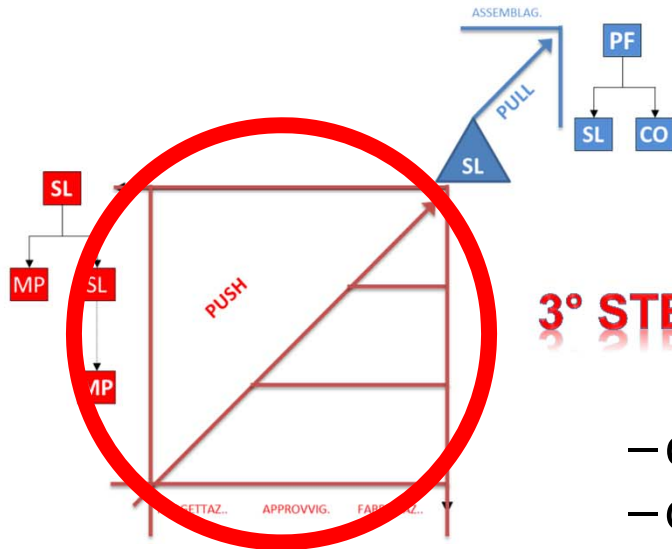

3° STEP: AFFIDABILITÀ DELLA SUPPLY CHAIN

- costruire "tubi di flusso" omogenei
- dimensionare e bilanciare i carichi
- agire sui fornitori
- rendere affidabile il livello di servizio delle SC



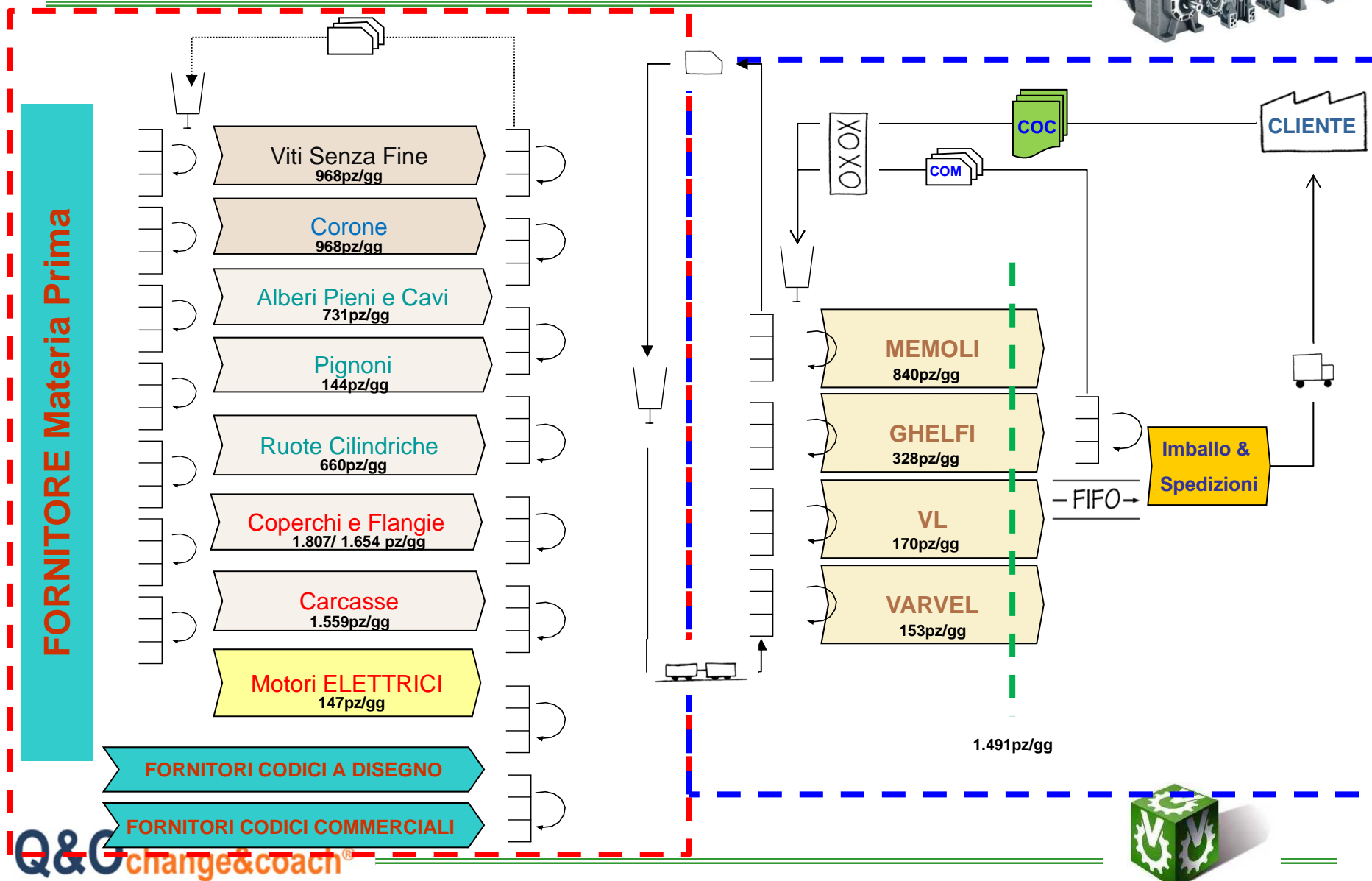



**i neuroni funzionano in modo più efficiente ...
quando si accendono in sincronia!**

